

Product Summary

V _{SS}	R _{SS(on)TYP}	I _S
20V	13.6mΩ@4.5V	8A
	14.0mΩ@4.0V	
	14.2mΩ@3.8V	
	15.3mΩ@3.1V	
	17.0mΩ@2.5V	

Feature

- Trench Technology
- Common-drain design
- Supper high density cell design
- ESD Diode-Protected Gate
- CSP

Application

- unidirectional or bidirectional load switch

MARKING:

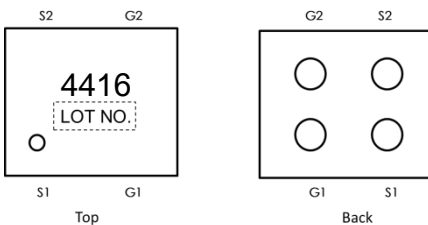

ABSOLUTE MAXIMUM RATINGS (T_A = 25°C unless otherwise noted)

Parameter	Symbol	Value	Unit
Source - Source Voltage	V _{DS}	20	V
Gate - Source Voltage	V _{GS}	±12	V
Source Current	DC ¹	I _S	8
	Pulse ^{1,2}	I _{SP}	60
Total Power Dissipation ¹	T _A = 25°C	P _T	1.5
Junction Temperature	T _J	150	°C
Storage Temperature	T _{STG}	-55~ +150	°C

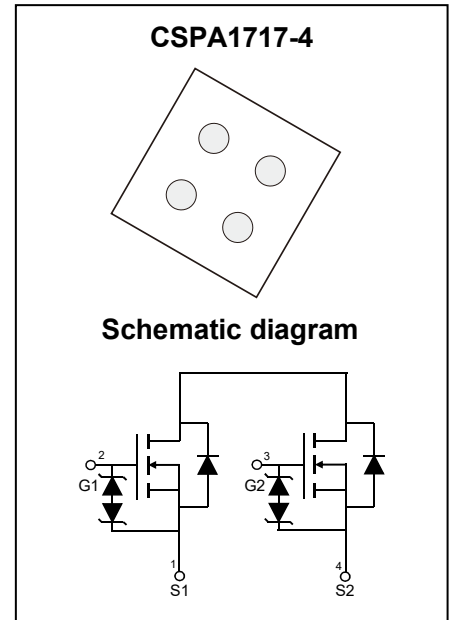

MOSFET ELECTRICAL CHARACTERISTICS (T_A = 25°C unless otherwise noted)

Parameter	Symbol	Test Condition	Min	Type	Max	Unit
Off Characteristics						
Drain - Source Breakdown Voltage	BV _{SSS}	V _{GS} = 0V, I _S = 250μA	20			V
Zero Gate Voltage Drain Current	I _{SSS}	V _{SS} = 20V, V _{GS} = 0V			1	μA
Gate - Body Leakage Current	I _{GSS}	V _{GS} = ±8V, V _{SS} = 0V			±3	μA
On Characteristics						
Gate Threshold Voltage	V _{GS(th)}	V _{DS} = V _{GS} , I _S = 250μA	0.5	0.7	1.3	V
Drain-source On-resistance	R _{SS(on)}	V _{GS} = 4.5V, I _S = 1A	9.5	13.6	17.0	mΩ
		V _{GS} = 4.0V, I _S = 1A	10.0	14.0	17.5	
		V _{GS} = 3.8V, I _S = 1A	10.5	14.2	18.0	
		V _{GS} = 3.1V, I _S = 1A	11.0	15.3	19.5	
		V _{GS} = 2.5V, I _S = 1A	12.0	17.0	23.0	
Dynamic Characteristics						
Input Capacitance	C _{iSS}	V _{SS} = 10V, V _{GS} = 0V, f = 1MHz		1496		pF
Output Capacitance	C _{oSS}			193		
Reverse Transfer Capacitance	C _{rSS}			152		
Gate Resistance	R _g	V _{SS} = 0V, V _{GS} = 0V, f = 1MHz		217		Ω
Switching Characteristics³						
Total Gate Charge	Q _g	V _{SS} = 10V, V _{GS} = 4.5V, I _S = 5A		27		nC
Gate-source Charge	Q _{g1s1}			3.3		
Gate-drain Charge	Q _{g1s2}			5.6		
Turn-on Delay Time	t _{d(on)}	V _{DD} = 10V, V _{GS} = 4.5V, R _L = 3Ω		0.4		μs
Turn-on Rise Time	t _r			0.6		
Turn-off Delay Time	t _{d(off)}			2.5		
Turn-off Fall Time	t _f			1.0		
Source - Drain Diode Characteristics						
Diode Forward Voltage ³	V _{F(S-S)}	V _{GS} = 0V, I _S = 1A			1.0	V

Notes :

1. Mounted on FR4 board (25.4mmX25.4mmXt1.0mm) using the minimum recommended pad size (36um Copper).
2. t = 10ms, Duty Cycle = 1%.
3. When FET1 is measured, G2 and S2 are short-circuited.

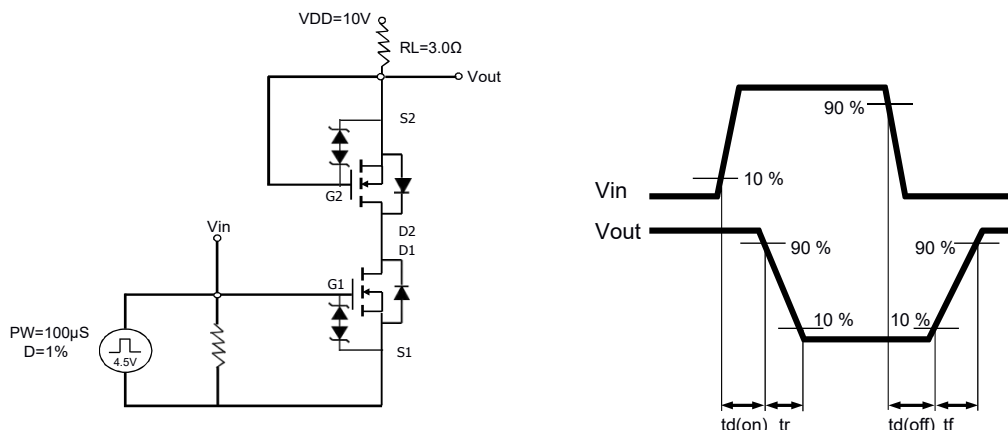

Typical Characteristics

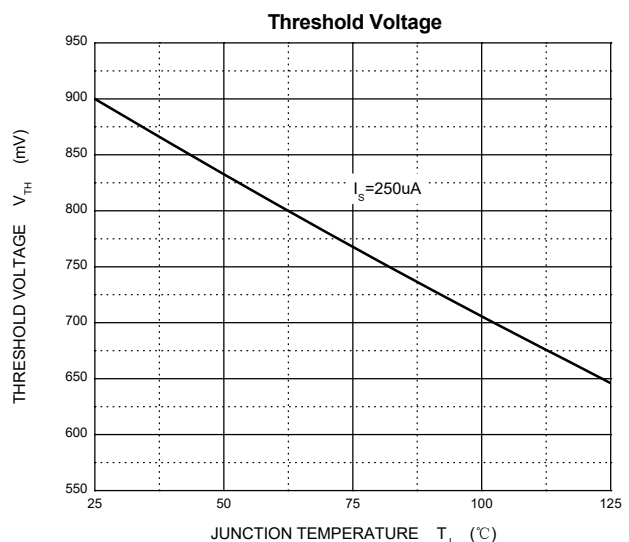
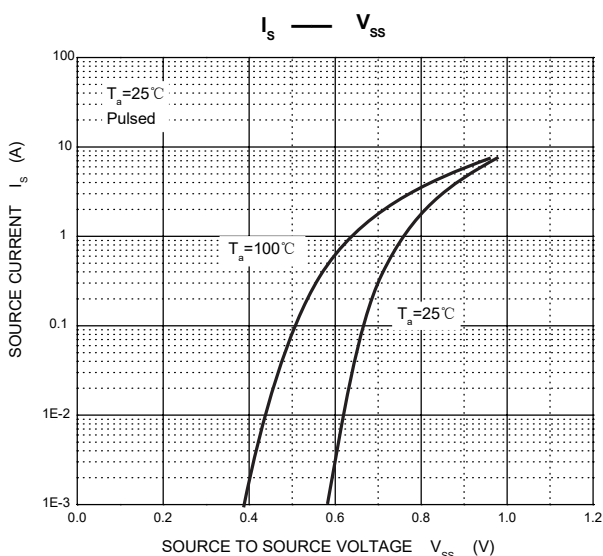
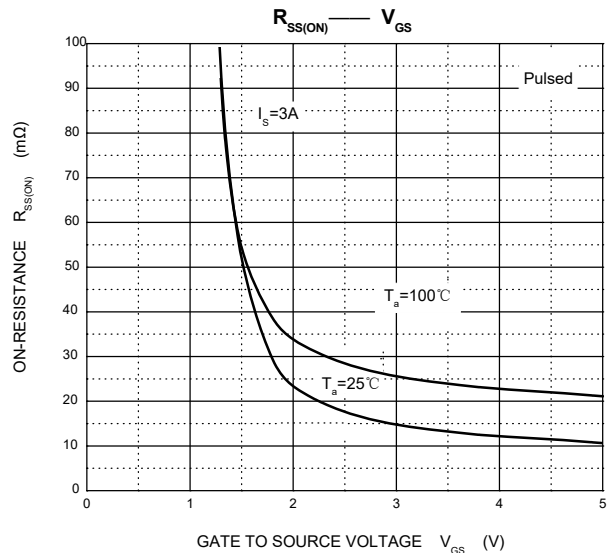
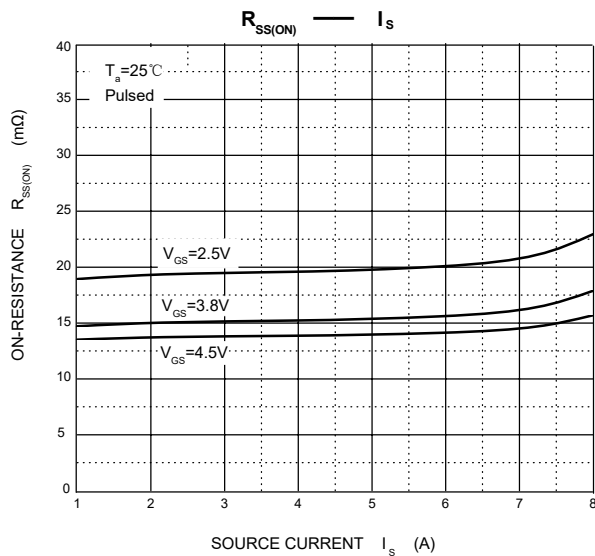
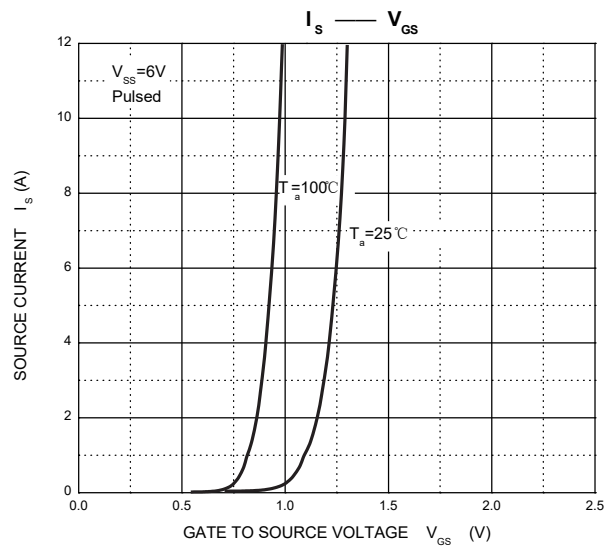
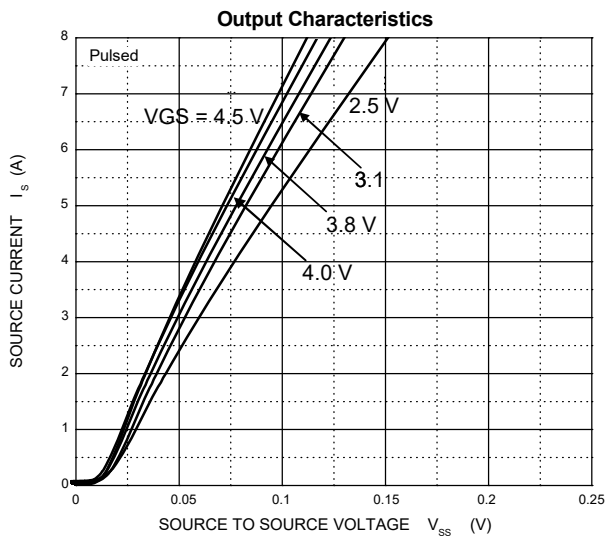

TOTAL POWER DISSIPATION vs. AMBIENT TEMPERATURE

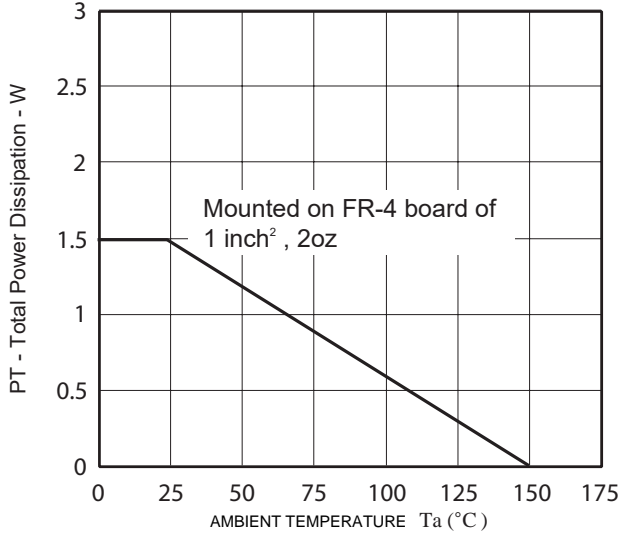

Maximum Safe Operating Area

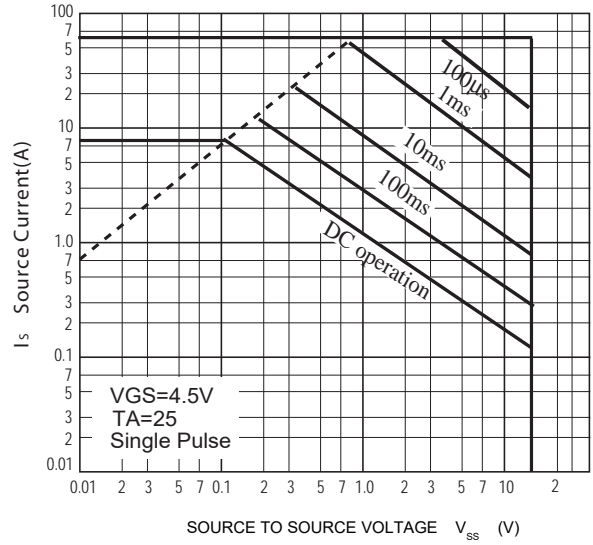

$R_{ss(ON)}$ — T_a

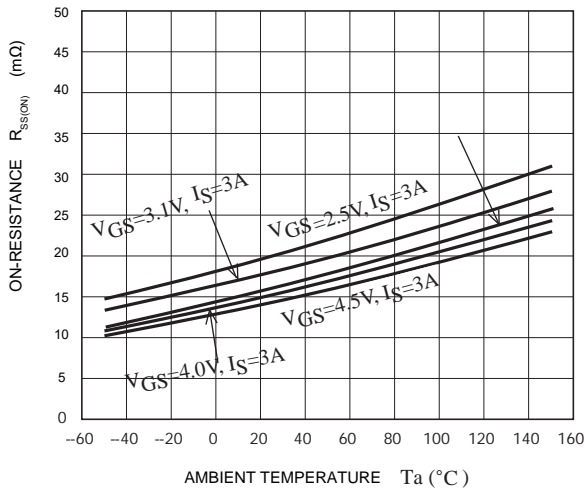

Capacitances

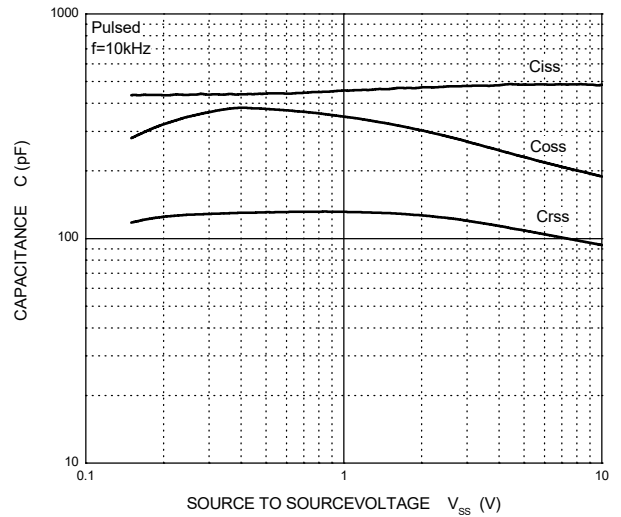

CSPA1717-4 Package Information

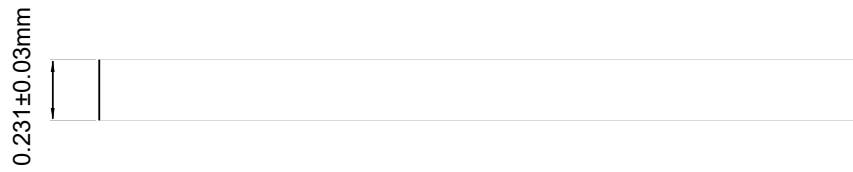
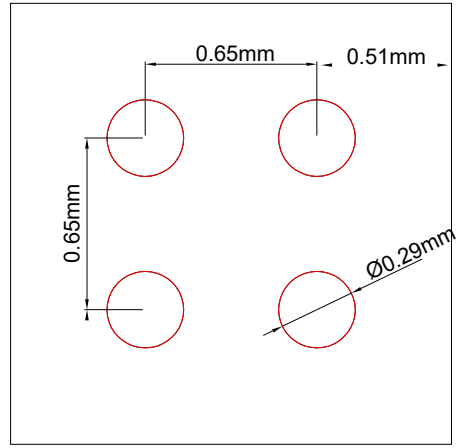
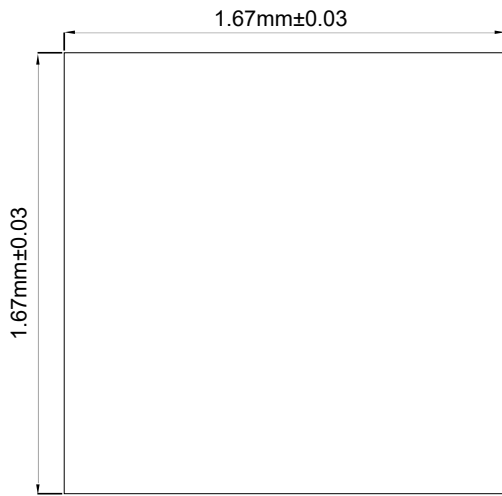

Attention:

- GreenPower Electronics reserves the right to improve product design function and reliability without notice.
- Any and all semiconductor products have certain probability to fail or malfunction, which may result in personal injury, death or property damage. Customer are solely responsible for providing adequate safe measures when design their systems.
- GreenPower Electronics products belong to consumer electronics or other civilian electronic products.